

MLR327_AL - MLR336_AL Series Anti Ligature Straight Grab Rails

Material Specifications

- #304 Stainless Steel - 32mmØ
- 2.0mm Thick Stainless Steel In Fill Plate

Dimensions

- **MLR327_AL:** 300mm C to C
- **MLR330_AL:** 450mm C to C
- **MLR331_AL:** 600mm C to C
- **MLR332_AL:** 750mm C to C
- **MLR333_AL:** 900mm C to C
- **MLR336_AL:** 1500mm C to C

Mounting

- Screw Fix - Multiple Points

Installation Guidelines

- *May be subject to Australian Building Code Regulations for height and location fixing and may be subject to placement as per architectural drawings. In all cases, this is the responsibility of the installer.*
 - *Anchors are not included with the units and are the responsibility of the installer to appropriately fix the unit to the wall.*
1. Locate fixing position on wall or partition and mark using mounting holes, ensuring the unit is level.
 2. Mount the unit to the wall using appropriate fixings (not supplied).
 3. Check the unit is level to finish installation.

NOTE:

- This unit is accessible compliant when installed in accordance with AS1428.1. guidelines.
- It is the responsibility of the installer to ensure that the surface/substrate that the unit is installed upon and the fixings used are suitable to withstand the weight bearing loads of the unit and if required as per AS1428 / Australia building code regulations.
- Compliant with the Force Requirements within AS1428.1:2021, Section 14.

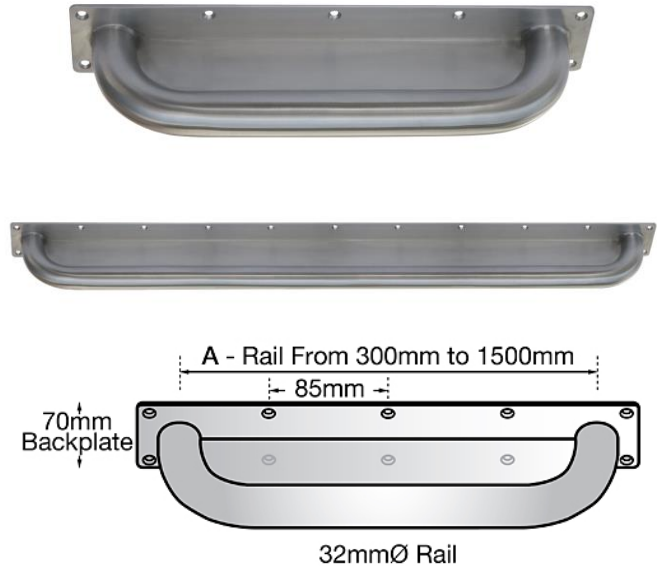

The technical recommendations contained in this document are necessarily of a general nature and should not be relied on for specific applications without first securing competent advice. Whilst Metlam Australia Pty Ltd has taken all reasonable steps to ensure the information contained herein is accurate and current, it does not warrant the accuracy or completeness of the information and does not accept liability for errors or omissions. Any Commercial product should only be installed by a competent tradesperson and serviced/maintained by knowledgeable janitorial staff or competent people. Metlam Australia accepts no responsibility for any damage to product, walls or fixtures due to incorrect installation or maintenance of any of their products.

The photographs and line drawings of the products presented above are representational only.
Metlam Australia Pty Ltd reserves the right to, and from time to time, make changes and improvements in design and dimensions.